

Temperature Transceiver Node Wireless 9 RTD & PRT Sensor Transmitter

Phase IV Data Sheet Leap Sensors® 9 RTD & PRT Temperature Node

Applications

- Temperature gradient monitoring
- Silicon wafer temperature monitoring
- Precision temperature monitoring of multiple points

Special Features

- Sensor transmission range of 1,500 ft. in open air at full power
- Configurable to power and transmit any PRT or RTD sensor type
- Edge computing for small, actionable data
- Configurable sample and transmit intervals to fit many application requirements
- Simple integration into existing Leap Sensor systems
- Transceiver nodes factory preconfigured to pair with new or existing gateway for simple integration – up and running in 5 minutes
- LED indicators on transceiver node for power, network connection, gateway connection, and database connection status

Description & Product Highlights

Phase IV's Leap Sensors RTD Temperature Transceiver Node is ideal for any remote temperature monitoring application that requires a high level of precision and accuracy with 2 to 9 high-precision temperature probes. User configurable sample and transmit rates as well as event triggered rapid sampling conditions give the user powerful insight to prevent failure conditions.

The Leap Sensors wireless sensor system greatly reduces the cost and complexity of laying cables between sensors and data acquisition units. Wireless communication is much better suited for small, actionable data to trigger alerts.

A single 3-wire RTD circuit allows for remote monitoring of up to 9 different temperature points on high-value equipment and product.

The Leap Sensors system is intended primarily for the purpose of performing industrial sensor measurements.



9 RTD/PRT Temperature Node

Modularity and customizability

Each RTD Node has the capability to support and interface with both class A and class B RTDs. In addition, semi-custom solutions can be created leveraging our multi-sensor base board to expand sensor interfacing capabilities, utilizing many other sensor types.

Ease of implementation

All Leap Sensors device nodes come pre-configured and paired with selected Leap Sensors gateways for quick and simple integration into an existing Leap Sensors system, or to function as a new stand-alone system. Custom firmware loaded on the device can configure the data viewing software to accept any and all new device types.

Real-time data viewing and alerts

All Leap Sensors nodes stream data to Leap Sensors gateway devices at configurable intervals. This data is accessible and viewable in real time. In addition to real-time viewing and graphing of sensor parameters, alerts based on any sensor condition are configurable, and can be sent via phone call, email, or text for instant communication of a sensor reaching an alert condition.

Leap Sensors® RTD / PRT Node Specifications	
General Sensor Specifications*	
PRT / RTD Inputs	Class B RTD standard, Class A RTD optional
Sensor Range	-200 °C - 420 °C (calibrated, contact factory for custom cal. ranges)
Accuracy	Typical: +/- 1C. Verified at 3 points
Output units	Temperature in C, K, F, R
Power Specifications	
Battery Power	3.6 V, 14,000 mAh D-cell, Lithium Thionyl Chloride or 3 thin coin cells
Battery Life	5 years at 10 minute transmit & sample intervals. On-board battery passivation prevention circuit assures long life.
Power / Current Consumption	Low sleep current assures long life Typical Operating Current: 6mA - 30mA (depending on sensors) Typical Transmit Current: 9mA @ 0dBm and 80mA @ 20 dBm RX Current: 11 mA
Wireless Specifications	
Wireless Transmission Range	Industrial Environments** Open-Air**
	500 ft 1,500 ft – full power
Range Extenders	Range extenders available to extend transmission distance
RF Transmission Power	User configurable 0-20 dBm, factory configured to 20 dBm***
RF Communication Protocol	Internet protocol-based thread, IPV6LoWPAN, IEEE 802.15.4
RF Frequency and Modulation	2.4 GHz (16 Channels), DSSS provides higher noise and interference resistance
Data Security	AES 128-bit encryption with secure join and key exchange (J-PAKE)
Internal Electronics Features	
Operating Temp.	- 40 °C to 60 °C, -40°C to 120°C available – special order
Gateway Compatibility	Compatible with all Leap Sensors wireless gateway
Firmware	Over-the-air upgradeable via web interface
Certifications	FCC (USA), IC (Canada)
Gateway Communication	Send and receive (data, acknowledgements, updates, and device configuration). Data stored in node until confirmed write to database.
LED Power Switch	Recessed in the enclosure to prevent accidental power cycling. On-switch is recessed. Off-switch flush with surface. Immediately resets transceiver node when turned off. Integrated green and red LED indicate wireless connection status at power-up.
Internal Memory	110,000 time-stamped device readings stored on transceiver node if gateway does not acknowledge writing data to database.
Enclosure & Hardware Specifications	
Dimensions	113 mm x 80 mm x 60 mm Thin version <5 mm thick
Weight	355g typical for complete transceiver node
Material	Polycarbonate (UL 94 rated and 120C rated)
Mounting Options	Optional feet (shown in drawing) can be mounted horizontally or vertically. Screws can also be passed through the enclosure (when the lid is open) for mounting without feet.
Ingress Protection	IP68 enclosure. IP67 glands, cables, switch
Node Antenna	Internal antenna (typical). External antenna (optional)

[Outbound sensor data, inbound device configurations, firmware updates, and transmission acknowledgements]

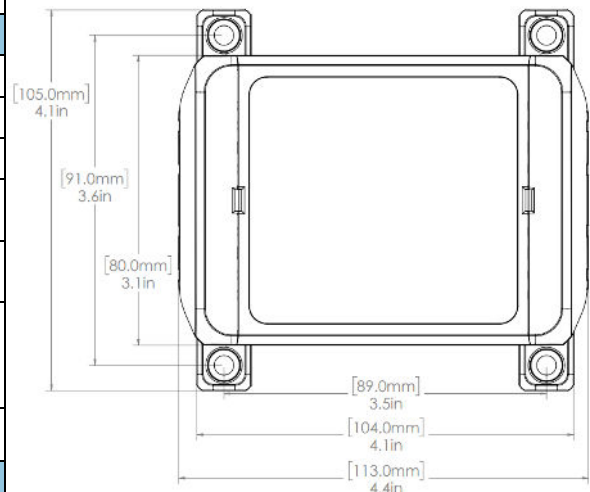
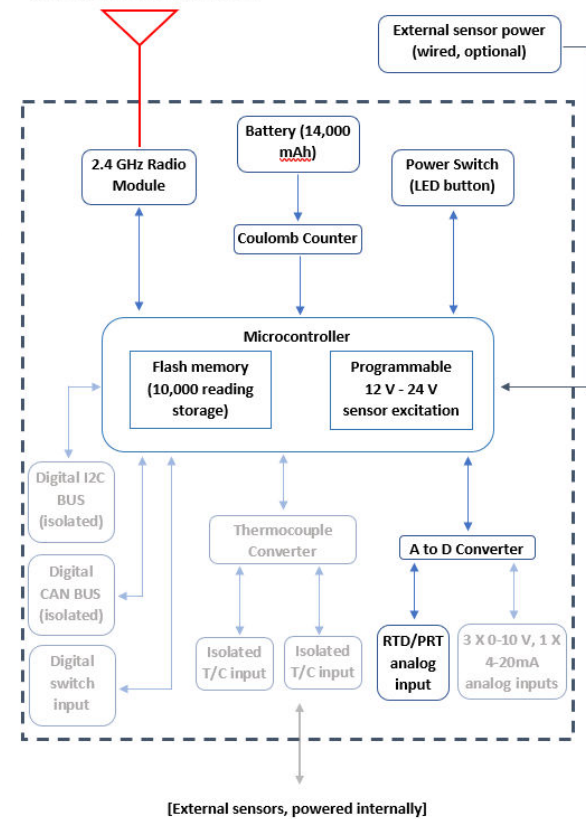

* Custom RTD's/PRT's configurable and available for different sensing and calibration ranges.

** Transmission ranges vary with environmental conditions. Reported values are test averages.