

# Temperature & Humidity Wireless Transceiver Node Customizable Analog & Digital Sensor Transmitter

Phase IV Data Sheet Leap Sensors® Temperature & Humidity Transceiver Node

## Applications

- **Product Storage Monitoring:** optimization of item storage conditions
- **Greenhouse Monitoring:** optimization of grow conditions
- **Lab Monitoring:** continuous verification of critical lab conditions
- **Condensation Monitoring:** monitors the presence of condensation and mold growth in damp rooms & areas

## Special Features

- Sensor transmission range of 1,500 ft. in open air
- Edge computing for small, actionable data
- Configurable sample and transmit intervals to fit many application requirements
- Simple integration into existing Leap Sensor systems
- Transceiver nodes are factory preconfigured to pair with new or existing gateway for simple integration – up and running in 5 minutes.
- LED indicators on transceiver node for power, network connection, gateway connection, and database connection statuses.

## Description & Product Highlights

Phase IV's Leap Sensors Temperature and Humidity Transceiver Node is the critical for environmental condition monitoring. The node can function as a stand-alone monitoring sensor or be configured to monitor additional parameters important to the specific application.

Additional accessories enhance the effectiveness of this monitoring system. Customizable flat ribbon cables and panel connectors allow for rapid replacement of calibrated probe tips and allow minimal effect on controlled environments by the sensor cable.

Additional sensors can be easily interfaced to the same node due to the baseboards modular, multi-sensor design. Contact Phase IV if a non-standard sensor is required.

The Leap Sensors system is intended primarily for the purpose of performing industrial sensor measurements.



## Temperature & Humidity Transceiver Node Model

### Modularity and customizability

Each temperature and humidity device can be custom configured to include up to two switching input sensors, as well as an additional I2C bus sensor. Off-the-shelf options include an open door sensor, a differential pressure sensor, or an additional temperature and humidity probe.

### Ease of implementation

All Leap Sensors device nodes come pre-configured and paired with selected Leap Sensors gateways for quick and simple integration into an existing Leap Sensors system, or to function as a new stand-alone system. The humidity monitoring system comes with an optional replaceable calibrated probe tip, simplifying calibration procedures, ensuring traceability, and drastically reducing lead times.

### Real-time data viewing and alerts

All Leap Sensors transceiver nodes stream data to Leap Sensors gateway devices at configurable intervals. This data is accessible and viewable in real time. In addition to real-time viewing and graphing of sensor parameters, alerts based on any sensor condition are configurable, and can be sent via phone call, email, or text for instant communication of a sensor reaching an alert condition.

Leap Sensors® Temperature & Humidity Node Specifications		
<b>Digital Temperature Sensor Specifications</b>		
Sensor Head Dimensions	0.25" Diameter, 1.25" Length	
Probe Sensing Range	-40 °C to 85 °C	
Accuracy	Typical: ±0.3°C at 5°C to 60°C, ±1.0°C at -20°C to 85°C	
Connector Interface	Industrial IP67 4 pin M8 connector	
<b>Relative Humidity Sensor Specifications.</b>		
Sensor Head Dimensions	~0.28" wide, on a cable ~2.5" below the enclosure	
Sensing Range	1 % - 100 % relative humidity	
Accuracy	Typical: ±2% at 25°C (20% - 80% RH), ±4% at 5°C to 45°C (0% - 100% RH)	
<b>Power Specifications</b>		
Battery Power	2 X AA alkaline batteries, 5700 mAh	
Battery Life	4-5 years at 10-minute sample and transmit intervals	
Power / Current Consumption	Low sleep current assures long life Typical Operating Current: 6mA - 30mA (depending on sensors) Typical Transmit Current: 9mA @ 0dBm and 80mA @ 20 dBm RX Current: 11 mA	
<b>Optional Wall Power Specifications</b>		
Power Adaptor	5 VDC, 1500 mW max	
Barrel Jack	2.5 mm ID barrel connector (5 VDC - 3A AC/DC converter included)	
<b>Wireless Specifications</b>		
Wireless Transmission Range	Industrial Environments**	Open-Air**
	500 ft	1,500 ft
Range Extenders	Range extenders available to extend transmission distance.	
RF Transmission Power	User configurable 0-20 dBm, factory configured to 20 dBm***	
RF Communication Protocol	Internet protocol-based thread, IPV6LoWPAN, IEEE 802.15.4	
RF Frequency and Modulation	2.4 GHz (16 Channels), DSSS provides higher noise and interference resistance	
Data Security	AES 128-bit encryption with secure join and key exchange (J-PAKE)	
<b>Other Features</b>		
Operating Temp.	- 40 °C to 60 °C, -40°C to 120°C available – special order	
Gateway Compatibility	Compatible with all Leap Sensors wireless gateways	
Firmware	Over-the-air upgradeable via web interface	
Gateway Communication	Send and receive (data, acknowledgements, updates, and device configuration). Data stored in gateway until confirmed write to database.	
LED Power Switch	Recessed in the enclosure to prevent accidental power cycling. On-switch is recessed. Off-switch flush with surface. Immediately resets transceiver node when turned off. Integrated green and red LED indicate wireless connection status at power-up.	
Internal Memory	110,000 time-stamped device readings stored on transceiver node if gateway does not acknowledge writing data to database.	
<b>Enclosure &amp; Hardware Specifications</b>		
Dimensions	113 mm x 80 mm x 60 mm	
Weight	355g typical for complete transceiver node	
Material	Polycarbonate (UL 94 rated and 120C rated)	
Mounting Options	Optional feet (shown in drawing) can be mounted horizontally or vertically. Screws can also be passed through the enclosure (when the lid is open) for mounting without feet.	
Ingress Protection	IP68 enclosure. IP67 glands, cables, switch	
Node Antenna	Internal antenna (typical). External antenna (optional)	

[Outbound sensor data, inbound device configurations, firmware updates, and transmission acknowledgements]

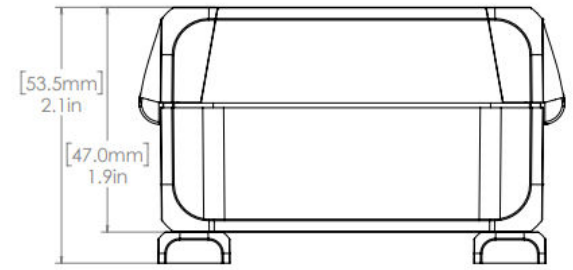
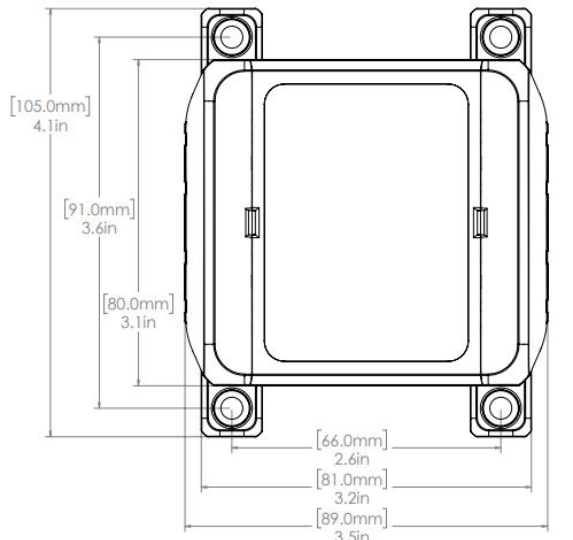
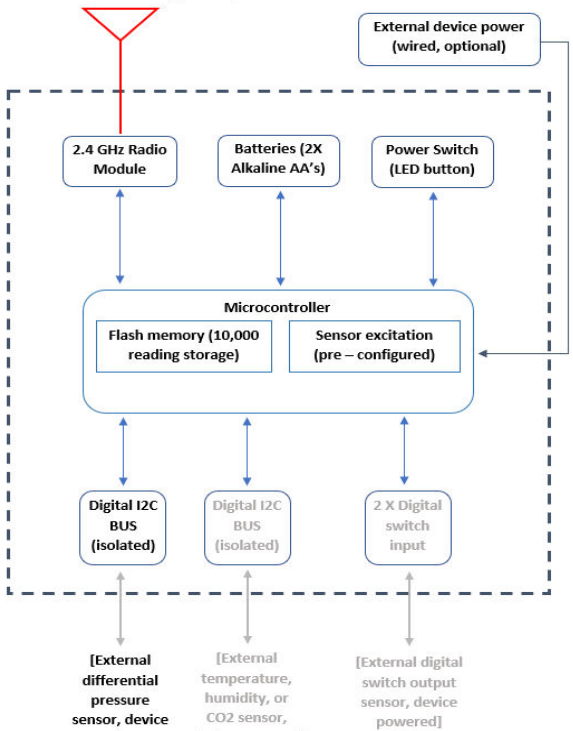

\* Panel connections are customizable, consult factory for complete options.  
 \*\* Transmission ranges vary with environmental conditions. Reported values are test averages.  
 \*\*\* Transmission power requirements are governed regionally.